

TEST OF ELECTRON LINAC FOR VEPP-5 PRE-INJECTOR

V.E. Akimov, A.V. Antoshin, M.S. Avilov, A.V. Aleksandrov, P.A. Bak, O.Yu. Bazhenov, Yu.M. Boimelshtein, D.Yu. Bolkhovityanov, A.G. Chupyra, N.S. Dikansky, A.R. Frolov, R.Kh. Galimov, R.G. Gromov, K.V. Gubin, S.M. Gurov, Ye.A. Gusev, I.V. Kazarezov, V.D. Khambikov, S.N. Klyushev, N.A. Kiseleva, V.I. Kokoulin, M.B. Korabelnikov, A.A. Korepanov, V.I. Kopylov, A.N. Kosarev, N.Kh. Kot, N.N. Lebedev, P.V. Logatchev, A.N. Lukin, P.V. Martyshkin, L.A. Mironenko, A.A. Nikiforov, A.V. Novokhatski, V.M. Pavlov, I.L. Pivovarov, O.V. Pirogov, V.V. Podlevskikh, S.L. Samoilo, V.S. Severilo, V.D. Shemelin, S.V. Shiyankov, B.A. Skarbo, A.N. Skrinsky, B.M. Smirnov, A.N. Sudarkin, D.P. Sukhanov, A.S. Tsyganov, Yu.V. Yudin, N.I. Zinevich. Budker INP, 630090, Novosibirsk, Russia

Abstract

The results of the basic tests of VEPP-5 pre-injector electron linac are presented. The main elements of the linac were tested at the designed parameters. The electron beam energy up to 105 MeV after 3-meter long accelerating structure was obtained.

1 INTRODUCTION

This paper presents the results of basic test of initial part of pre-injector [1] (first accelerating assembly) that includes electron gun, subharmonic buncher, S-band buncher, three accelerating sections, RF assembly on the basis of 5045 SLAC klystron, pulse compression system, focusing system and a system of beam diagnostics (see Fig 1). To get the maximum acceleration rate, all RF power after the compression system is directed into the first accelerating section. The rest two sections and the subharmonic buncher were out of operation in present experiments and were used as the beam transportation channel.

2 ACCELERATING SECTION

The accelerating section (AS) of VEPP-5 pre-injector is managed as of a round disk-loaded waveguide of constant impedance (the constant cell geometry along the AS). Two wave type transformers (WTT) placed at the input and the output of the section. WTT transforms the basic mode of waveguide channel H_{10} into the accelerating mode E_{01} of a round disk-loaded waveguide. To reduce the overvoltage ratio, the edge of the iris is performed as an ellipse with the half-axis ratio 1:2 (see Fig. 2).

The section was assembled of two identical parts 1.5 m length each. Brazing of each part was carried out in the vacuum furnace. Both brazed half-sections were welded together via the connecting iris, as shown in Fig.3.

Both sides of connecting iris were covered by the golden film. The iris was tighten between the special connecting cells up to formation of the thermal diffusion

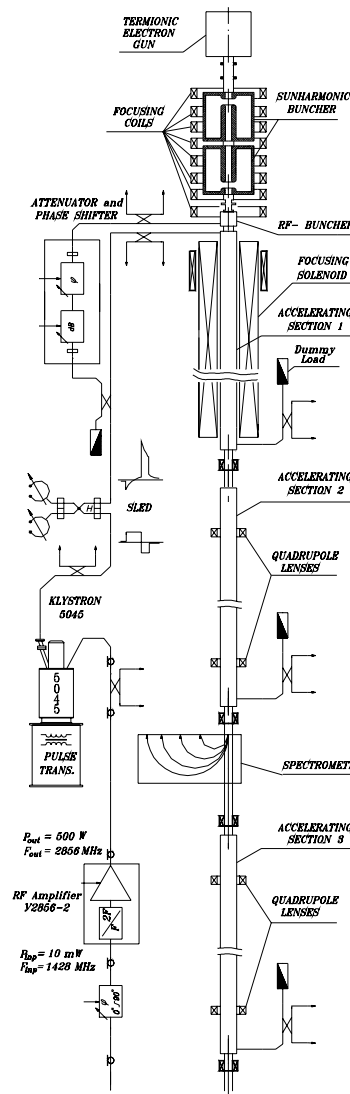

Fig.1 The scheme of RF test accelerating section seam. Then, in order to provide the mechanical strength, the welding of steel rings was done. The AS parameters are presented in Table 1.

Table 1. Parameters of the accelerating section.

Operational frequency	2855.5 MHz
Internal cell diameter $2b$	83.75 mm
Iris diameter $2a$	25.9 mm
Iris thickness t	6 mm
Period D	34.99 mm
Operational mode of oscillation θ	$2\pi/3$
Relative phase velocity β_p	1
Relative group velocity β_g	0.021
Section length L	2.93 m
Total number of cells (incl. 2 WTT)	85
Unloaded quality factor Q_0	13200
Shunt impedance R_{sh}	51 Mohm/m
Time constant $\tau_{gr}=2Q_0/\omega_0$	1.471 μ s
Attenuation (by field) $\alpha=1/(\tau_{gr}v_{gr})$	0.108 m^{-1}
Filling time $T_f=L/v_{gr}$	0.465 μ s

Before the experiments, the AS and all waveguide channels were baked for 3 days at the temperature $t \approx 230^\circ\text{C}$. After the baking and RF processing, the vacuum of $\sim 3 \cdot 10^{-9}$ Torr was achieved.

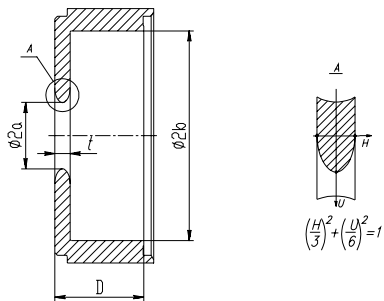

Fig. 2. Geometry of accelerating section's cell.

3 RF POWER SUPPLY OF THE ASSEMBLY

The continuous RF signal ($f = 1428$ MHz, $P \approx 10$ mW) from the master oscillator is directed to the shaping amplifier assembly U2856-2 via 90° phase shifter. The shaping amplifier operates at the doubled frequency 2856 MHz and forms the RF pulse of ~ 3.5 μ s duration and output pulsed power $P \approx 200$ – 400 W for 5045 klystron excitation. Phase shifter provides the phase inversion at the operational frequency at the given instant to ensure the power compression system operation. RF pulse of up to 60 MW power is directed from the klystron along the waveguide channel (72 x 34 mm) via the SLED-type power compression system, to the AS input. The unused power in the AS is dissipated in the dummy load that is located at the output of the section. The fraction of RF power after SLED system is directed to the RF buncher via the directional coupler with the attenuation $\alpha_c = 23$ dB.

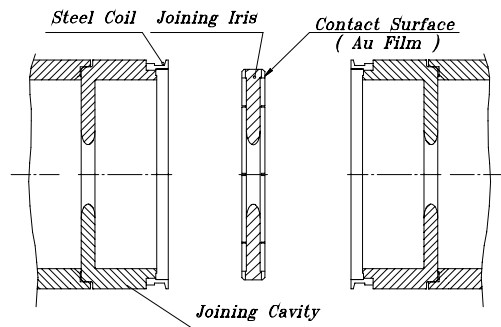

Fig. 3. Connection of two AS parts.

RF pulse phase and amplitude can be varied by means of the attenuator and phase shifter.

The temperature control of AS, load, RF buncher and SLED cavities is provided by the system of thermostabilization. The stabilization of temperature is provided by change of cooling distilled water temperature at the input of cooling systems. Operational temperature of AS is 30°C . Accuracy of temperature stabilization is $\pm 0.1^\circ\text{C}$.

4 HIGH VOLTAGE ELECTRON GUN

As a source of electrons, the three-electrode thermionic gun with the oxide cathode is used. Main parameters of the electron gun are presented in Tab.2.

Table 2. Main parameters of the electron gun.

Electron gun voltage	up to 200 kV
Current pulse width (FWHM)	2–350 ns
Pulsed current	up to 3 A
Repetition rate	up to 50 Hz

5 BEAM DIAGNOSTICS SYSTEM

System of beam diagnostics includes the measurements of following beam parameters: pulsed current and total charge of the beam from the electron gun, charge and energy characteristics of accelerated beam and also its position at the input and output of AS.

Gun pulsed current is measured by the wall current monitor located at the gun output.

Measurements of beam energy characteristics are made by means of 180° magnetic spectrometer. After spectrometer the beam was directed to the luminescent screen. One can define the energy of accelerated electrons by the value of magnetic field in the spectrometer and radius of turn. Also the beam energy spread can be evaluated by the size and relative brightness of the spot on the luminescent screen.

The charge of accelerated beam is measured by the Faraday cup, located after the luminescent screen.

The beam position at the input of the accelerating section was controlled by the luminescent screen at the input of AS, and by the band-type two-coordinate pick-up.

6 EXPERIMENTAL RESULTS

During the experiments the pulsed electron current injected in the section was $\approx 3A$ at the pulse width 2ns. For this pulse width the beam radiation field is low and doesn't influence essentially on the acceleration. The accelerating field in the AS is defined by the klystron input power only. At that operational conditions it is possible to reach the maximum accelerating gradient and, hence, the maximum energy of the accelerated beam. As an example, is shown in Fig.4, the pulse shape after the power compression system at the pulsed input power amplitude $P_{inp} = 50$ MW. The operational parameters of power compression system cavities are calculated by the shape of the pulse after the power compression system, using the method of regressive analysis:

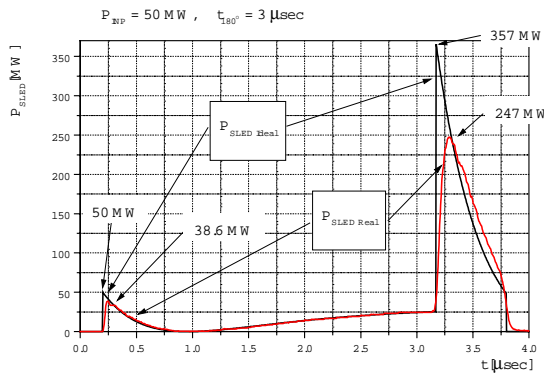

Fig. 4. Pulse shape after power compression system.

unloaded quality factor $Q_0 = 7.58 \cdot 10^4$;
 time constant $\tau_0 = 8.45 \mu s$;
 coupling ratio with the waveguide channel $\beta = 8.2$;
 time constant of loaded cavities $T_c = \frac{\tau_0}{1 + \beta} = 0.92 \mu s$;

and also typical times of input signal transient processes:
 $\tau_1 = 0.021 \mu s$ - typical time of growth of incident wave amplitude leading pulse edge;
 $\tau_2 = 0.044 \mu s$ - typical time of phase inversion.

Since at different instants of particle entrance in the AS the RF energy filling is different, then the beam passed through the AS has different energy gain depending on its instant of entrance in the AS. Fig.5 shows the beam energy W_{out} vs. the instant of entrance t in the AS.

At present time the short accelerated beam with $2 \cdot 10^{10}$ particles in the bunch is obtained at the output of the first AS. Maximum average accelerating gradient 35 MeV/m is reached. The maximum amplitude 50 MV/m of accelerating field in the first cells is achieved.

The AS operated at 5 Hz repetition rate (output energy of electrons 106 MeV) with a single breakdown for 40 minutes of operation, and without any breakdown at 50 Hz repetition rate (output energy 75 MeV). Fig.6-7

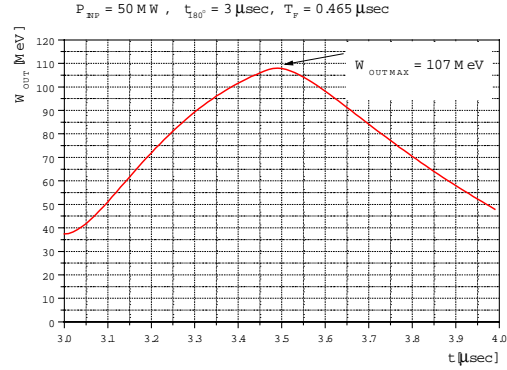

Fig. 5. Beam energy vs. instant of entrance in AS.

presents photos of luminescent screen for the accelerator operations with the RF buncher switched off and on. At the operation with RF buncher switched on the energy spread in the beam was $\pm 0.5\%$.

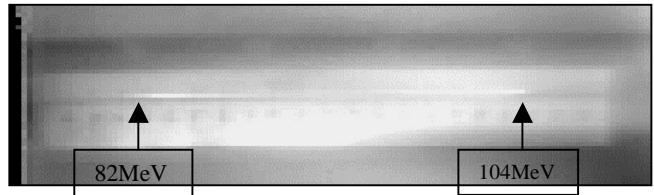

Fig.6. Accelerated beam with RF buncher switched off.

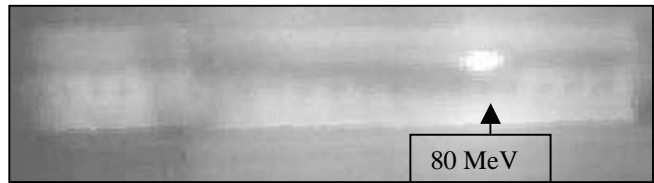

Fig.7. Accelerated beam with RF buncher switched on.

7 REFERENCES

- [1] A. Alexandrov et al., "Status of the injection complex for c-tau factory at Novosibirsk". Proceedings of the APAC'98, 23-27 March 1998, KEK, Tsikuba, Japan.